

Type 017710

Type 018810

Armaturen für Schiffbau und Industrie
Valves for shipbuilding and industry



Faltenbalg Absperrventile, PN 16
Durchgangs- oder Eckform
aus Grauguss GG-25
mit Faltenbalg aus Edelstahl
Baulänge nach DIN 3202/EN 558 T2
Flansche nach DIN PN 10/16
Zulässige Betriebsdrücke und
Temperaturen nach DIN 2401

Materialspezifikation:

Gehäuse:	GG-25	0.6025
Bügeldeckel:	GG-25	0.6025
Sitz:	Nirostahl	1.4021
Kegel:	Nirostahl	1.4021
Spindel:	Nirostahl	1.4021
Faltenbalg:	Edelstahl	1.4571

bellow sealed globe valves, PN 16
straight type or angle type
cast iron GG-25
with bellow in stainless steel
face to face acc. to DIN 3202/EN 558 T2
flanges acc. to DIN PN 10/16
working pressure and
temperature acc. to DIN 2401

material specification:

body:	GG-25	0.6025
bonnet:	GG-25	0.6025
seat:	stainless steel	1.4021
disc:	stainless steel	1.4021
stem:	stainless steel	1.4021
bellow:	stainless steel	1.4571

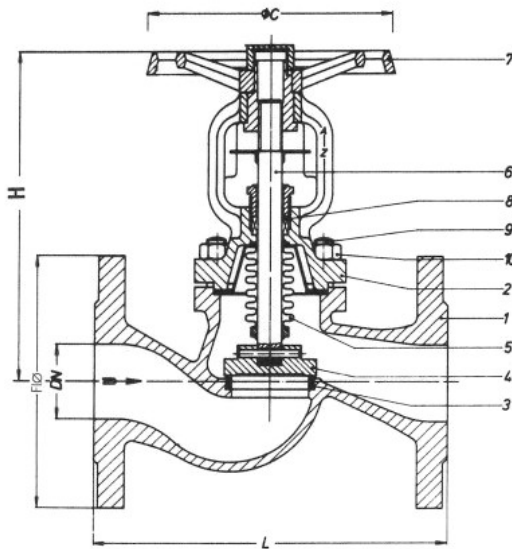

Type 017710

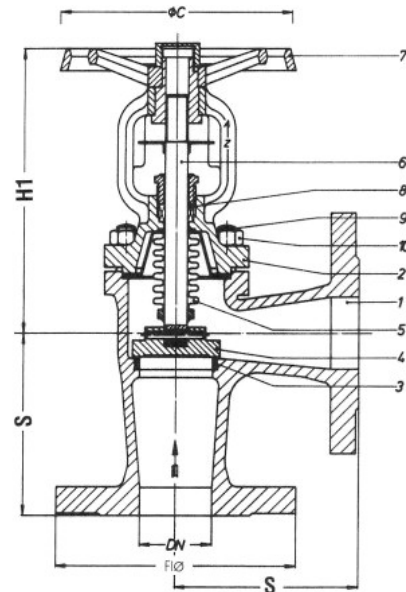

Type 018810

NW/DN	L	S	FIØ	PCD	Holes	H	H1	C	KG	KG
									017710	018810
15	130	90	95	65	4 x 14	195	166	125	3,5	3,7
20	150	95	105	75	4 x 14	195	166	125	4,0	4,4
25	160	100	115	85	4 x 14	195	172	125	4,5	5,1
32	180	105	140	100	4 x 18	193	175	125	6,0	6,5
40	200	115	150	110	4 x 18	232	193	160	9,0	8,3
50	230	125	165	125	4 x 18	235	195	160	12	11
65	290	145	185	145	4 x 18	283	213	200	18	15
80	310	155	200	160	8 x 18	285	227	200	23	19
100	350	175	220	180	8 x 18	350	294	250	37	31
125	400	200	250	210	8 x 18	389	325	250	53	44
150	480	225	285	240	8 x 22	440	355	315	79	58
200	600	275	340	295	8 x 22	570	440	400	147	99
250	730	325	395	350	12 x 22	665	580	520	180	161
300	850	375	445	400	12 x 22	720	620	520	265	235
350	980	425	505	460	16 x 22	860	785	640	360	300
400	1.100	475	565	515	16 x 26	1.010	910	640	615	570

Auf Wunsch zahlreiche Sonderausführungen möglich.
Several special executions possible on request.