

# Type 056070

Armaturen für Schiffbau und Industrie  
Valves for shipbuilding and industry



**Muffenschieber PN 20**  
**Schweres Modell „Rot-Gelb“**  
**aus Rotguss**  
**mit nichtsteigender Spindel**  
**und aufgeschraubtem Oberteil**  
**Innengewinde nach ISO 228/1**

**Materialspezifikation:**

Gehäuse:	Rotguss RG 5	2.1096
Oberteil:	Rotguss RG 5	2.1096
Keil:	Rotguss RG 5	2.1096
Spindel:	Messing MS58	2.0380
Handrad:	Zinkguss	-

**gate valve PN 20**  
**heavy pattern “red-white”**  
**bronze**  
**with non rising stem**  
**and screwed-on bonnet**  
**female screwed thread acc. to ISO 228/1**

**material specification:**

body:	bronze RG 5	2.1096
bonnet:	bronze RG 5	2.1096
wedge:	bronze RG 5	2.1096
stem:	brass MS58	2.0380
Handwheel:	zinc-casting	-

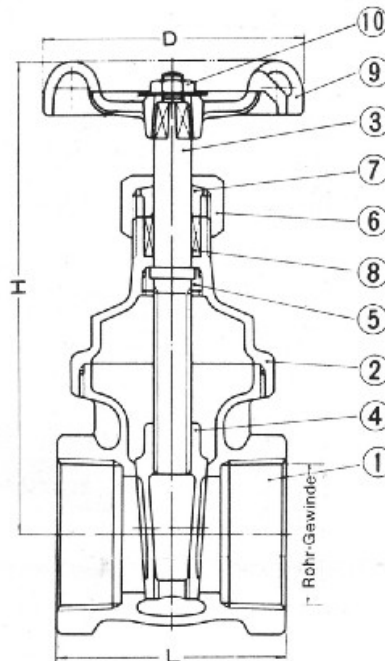

**Type 056070**

NW/DN	L	H	D	KG
G 3/8"	44	94	46	0,28
G 1/2"	46	90	46	0,31
G 3/4"	52	100	55	0,42
G 1"	58	115	63	0,61
G 1 1/4"	62	130	68	0,89
G 1 1/2"	66	148	78	1,20
G 2"	74	174	90	1,85
G 2 1/2"	90	205	98	2,95
G 3"	100	243	125	4,57