

Type 017040

Armaturen für Schiffbau und Industrie
Valves for shipbuilding and industry



**Hochdruck – Durchgangsventile PN 63 - 160
aus Stahlguss GSC-25
Innentteile Nirostahl
Baulänge nach DIN 3202/EN 558
Flansche nach DIN 2526, Form E (PN 63 – 160)
Zulässige Betriebsdrücke und
Temperaturen nach DIN 2401**

**high-pressure stop valves PN 63 - 160
cast steel GSC-25
inner parts stainless steel
face to face acc. to DIN 3202/EN 558
flanges acc. to DIN 2526 "E", PN 63 - 160
working pressure and
temperature acc. to DIN 2401**

Materialspezifikation:

Gehäuse:	GSC-25	1.0619
Bügeldeckel:	GSC-25	1.0619
Sitz:	Nirostahl	1.4301
Kegel:	Nirostahl	1.4021
Spindel:	Nirostahl	1.4021

material specification:

body:	GSC-25	1.0619
bonnet:	GSC-25	1.0619
seat:	stainless steel	1.4301
disc:	stainless steel	1.4021
stem:	stainless steel	1.4021

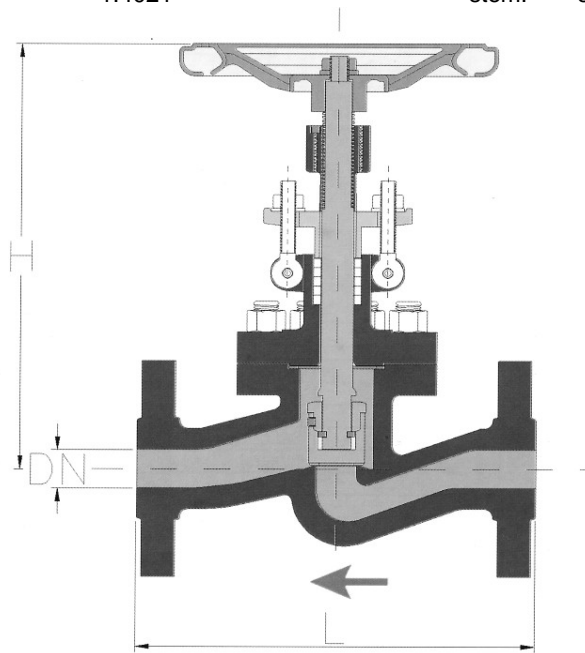

Type 017040

**Einsatz eines Entlastungskegels erforderlich, bei Betriebsdrücken höher als:
balanced disc necessary, if working pressure is higher than:**

DN:	065	080	100	125	150
Bar:	110	64	44	30	21

NW/DN	L	H	D			D			KG	
			PN 63	PCD PN 63	Holes PN 63	PN 100 PN 160	PCD PN 100 PN 160	Holes PN 100 PN 160	PN 63	PN 100 PN 160
15	210	260	105	75	4 x 14	105	75	4 x 14	10	10
20	220	285	130	90	4 x 18	130	90	4 x 18	16	16
25	230	300	140	100	4 x 18	140	100	4 x 18	18	18
32	250	325	155	110	4 x 22	155	110	4 x 22	20	20
40	260	365	170	125	4 x 22	170	125	4 x 22	28	28
50	300	385	180	135	4 x 22	195	145	4 x 26	32	36
65	340	415	205	160	8 x 22	220	170	8 x 26	48	70
80	380	440	215	170	8 x 22	230	180	8 x 26	56	82
100	430	490	250	200	8 x 26	265	210	8 x 30	86	118
125	500	550	295	240	8 x 30	315	250	8 x 33	126	160
150	450	630	345	280	8 x 33	355	290	12 x 33	160	205

Auf Wunsch zahlreiche Sonderausführungen möglich.
Several special executions possible on request.