

Type 017925

Type 018925

Armaturen für Schiffbau und Industrie
Valves for shipbuilding and industry



Absperrbare Rückschlagventile (SDNR), PN 16
in Durchgangs- oder Eckform, DIN 86252-02
aus Sphäroguss GGG40.3, Innenteile Rotguss RG 5
mit oder ohne innenliegende Schliessfeder
Baulänge nach DIN 3202/EN 558 F1/F32
Flansche nach DIN PN 10/16
Zulässige Betriebsdrücke und
Temperaturen nach DIN 2401

Materialspezifikation:

Gehäuse:	GGG40.3	0.7043
Bügeldeckel:	GGG40.3	0.7043
Sitz:	Rotguss RG 5	2.1096
Kegel:	Rotguss RG 5	2.1096
Spindel:	SoMs59	2.0540

screwdown check-valves (SDNR), PN 16
straight type or angle type, DIN 86252-02
nodular iron GGG40.3, inner parts bronze RG 5
with or without inside spring
face to face acc. to DIN 3202/EN 558 F1/F32
flanges acc. to DIN PN 10/16
working pressure and
temperature acc. to DIN 2401

material specification:

body:	GGG40.3	0.7043
bonnet:	GGG40.3	0.7043
seat:	bronze RG 5	2.1096
disc:	bronze RG 5	2.1096
stem:	special brass	2.0540

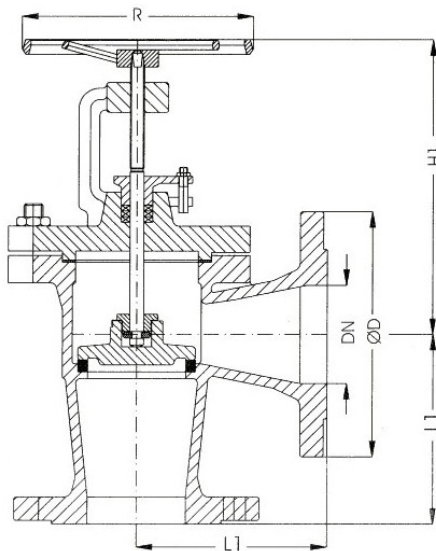

Type 018925
(Form B)

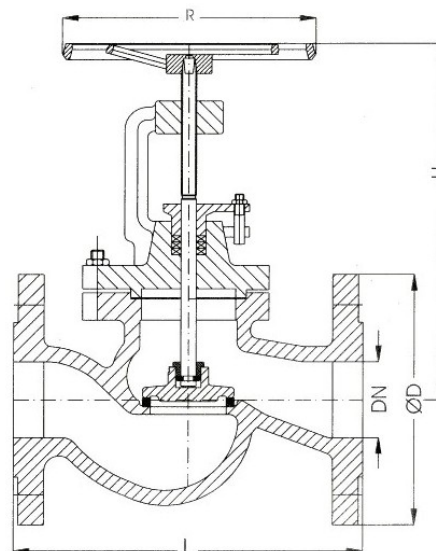

Type 017925
(Form A)

NW/DN	L	L1	D	PCD	Holes	H	H1	R	KG	
									017925	018925
15	130	90	95	65	4 x 14	172	155	100	3,3	5,0
20	150	95	105	75	4 x 14	168	163	100	3,8	5,5
25	160	100	115	85	4 x 14	192	185	120	5,4	7,5
32	180	105	140	100	4 x 18	210	212	140	8,0	9,0
40	200	115	150	110	4 x 18	225	212	140	9,4	11,0
50	230	125	165	125	4 x 18	245	224	160	13,6	14,0
65	290	145	185	145	4 x 18	282	274	160	18,0	20,0
80	310	155	200	160	8 x 18	337	340	240	31,0	34,0
100	350	175	220	180	8 x 18	378	377	240	40,0	42,0
125	400	200	250	210	8 x 18	438	422	280	62,0	61,0
150	480	225	285	240	8 x 22	470	485	320	86,0	85,0
175	-	-	-	-	-	-	-	-	-	-
200	600	275	340	295	8 x 22	570	574	360	153	134
250	730	325	395	350	12 x 22	691	691	400	207	200
300	850	375	445	400	12 x 22	760	550	520	277	247
350	980	425	505	460	16 x 22	860	630	520	530	300
400	1.100	475	565	515	16 x 26	880	780	520	600	570

Auf Wunsch zahlreiche Sonderausführungen möglich.
Several special executions possible on request.